

Brushless DC-Servomotors

with integrated Speed Controller

4 Pole Technology

20 mNm

For combination with
Gearheads:
22F, 22/7, 26A

Series 2250 ... BX4 S SC

	2250 S	024 BX4 S	SC
1 Nominal voltage	U_N	24	Volt
2 Terminal resistance, phase-phase	R	5,9	Ω
3 Output power ¹⁾	$P_{2 max.}$	10,3	W
4 Efficiency	$\eta_{max.}$	70,4	%
5 No-load speed	n_o	10 500	min ⁻¹
6 No-load current (with shaft \varnothing 3,0 mm)	I_o	0,105	A
7 Stall torque	M_H	84,7	mNm
8 Friction torque, static	C_o	0,75	mNm
9 Friction torque, dynamic	C_v	$1,4 \cdot 10^{-4}$	mNm/min ⁻¹
10 Speed constant	k_n	451	min ⁻¹ /V
11 Back-EMF constant	k_E	2,218	mV/min ⁻¹
12 Torque constant	k_M	21,1	mNm/A
13 Current constant	k_I	0,047	A/mNm
14 Slope of n-M curve	$\Delta n / \Delta M$	125,6	min ⁻¹ /mNm
15 Terminal inductance, phase-phase	L	250	μ H
16 Mechanical time constant	τ_m	6,97	ms
17 Rotor inertia	J	5,3	gcm ²
18 Angular acceleration	$\alpha_{max.}$	160	$\cdot 10^3$ rad/s ²
19 Thermal resistance	R_{th1} / R_{th2}	1,2 / 10,5	K/W
20 Thermal time constant	τ_{w1} / τ_{w2}	4,2 / 332	s
21 Operating temperature range		- 40 ... + 85	°C
22 Shaft bearings		ball bearings, preloaded	
23 Shaft load max.:			
- radial at 3 000 min ⁻¹ (4 mm from mounting flange)		20	N
- axial at 3 000 min ⁻¹		2	N
- axial at standstill		20	N
24 Shaft play:			
- radial	\leq	0,015	mm
- axial	$=$	0	mm
25 Housing material		stainless steel	
26 Weight		97	g
27 Direction of rotation		electronically reversible	
28 Number of pole pairs		2	
Recommended values - mathematically independent of each other			
29 Speed up to	$n_{e max.}$	12 500	min ⁻¹
30 Torque up to ^{1) 2)}	$M_{e max.}$	15 / 20	mNm
31 Current up to ^{1) 2)}	$I_{e max.}$	0,8 / 1,2	A

¹⁾ at 5 000 min⁻¹

²⁾ thermal resistance R_{th2} not reduced / thermal resistance R_{th2} by 55% reduced

Note:

The diagram indicates the recommended speed in relation to the available torque at the output shaft for a given ambient temperature of 22°C.

The diagram shows the motor in a completely insulated as well as thermally coupled condition (R_{th2} 55% reduced).

The motor is factory pre-configured to a continuous current for the thermally insulated condition. The controller must be reconfigured with the easy to use Motion Manager Software for use with other parameter settings.

The nominal voltage (U_N) curve shows the operating point at nominal voltage in the insulated and thermally coupled condition. Any points of operation above the curve at nominal voltage will require a higher operating voltage. Any points below the nominal voltage curve will require less voltage.

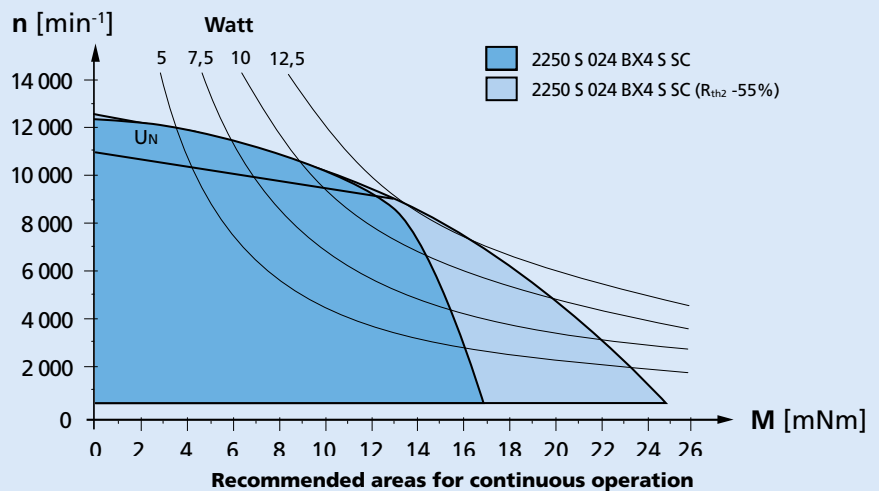

Dimensional drawing

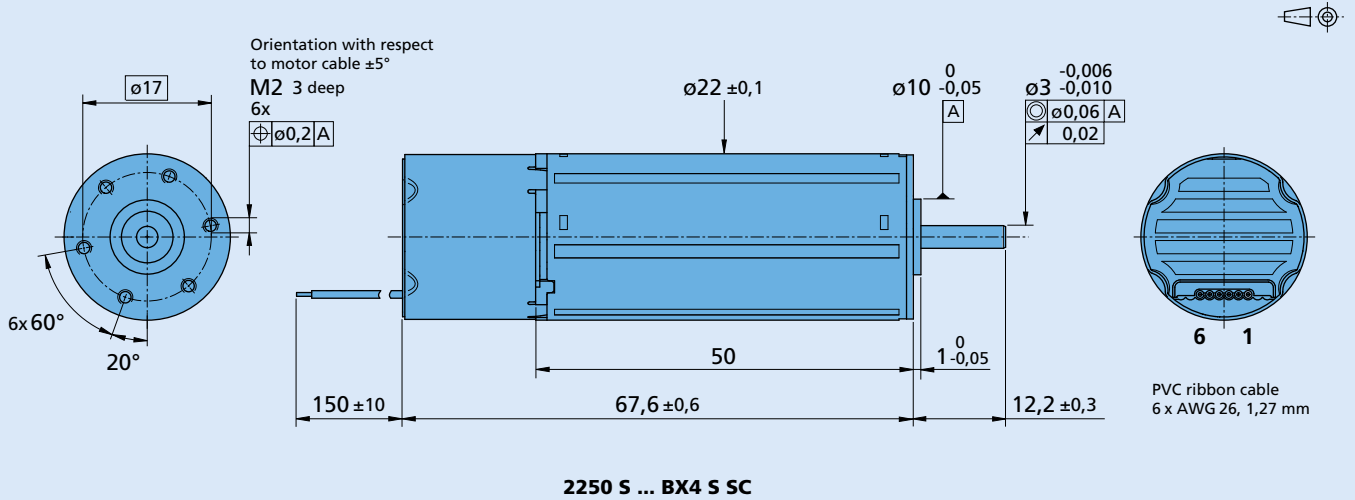

Speed Controller	024 BX4 S	SC
Power supply electronic	U_p 5 ... 28	V DC
Power supply motor	U_{mot} 6 ... 28	V DC
PWM switching frequency	f_{PWM} 96	kHz
Efficiency	η 95	%
Max. continuous output current ¹⁾	I_{dauer} 0,8	A
Max. peak output current ¹⁾	I_{max} 1,6	A
Total standby current at U_N	I_{el} 0,020	A
Speed range:		
– standard » Hall sensors (digital)	400 ... 50 000 ²⁾	min ⁻¹
Scanning range	500	μ s

¹⁾ at 22°C ambient temperature and max. 60°C motor temperature at the nominal voltage of motor and electronics

²⁾ speed depend on motor operating voltage

Connection information

Connection 1 "U_P":	power supply electronic	U_p
Connection 2 "U_{mot}":	power supply electronic coil	U_{mot}
Connection 3 "GND":	ground	ground
Connection 4 "U_{nsoll}":		
– analog input	input voltage	$U_{in} = 0 \dots 10V \mid > 10V \dots U_p$ » set speed value not defined
	input resistance	$R_{in} \geq 5k\Omega$
	set speed value	per 1V, 2 000 min ⁻¹
		$U_{in} < 0,15V$ » motor stops
		$U_{in} > 0,3V$ » motor starts
Connection 5 "DIR":		
– digital input	direction of rotation	to ground or level < 0,5V » counterclockwise
		open or level > 3V » clockwise
	input resistance	$R_{in} \geq 10k\Omega$
Connection 6 "FG":		
– digital output	frequency output	max. U_p ; $I_{max} = 15$ mA; open collector with 22 k Ω pull-up resistor
		6 lines per revolution

Features

In this variant, the brushless DC servomotors have an integrated Speed Controller. The motor is commutated using Hall sensors integrated into the motor. Speed control is via a PI regulator.

The Speed Controller has a current limiting device which limits the maximum motor current if the thermal load is too high. Twice the continuous current is possible over a short time.

Using the "FAULHABER Motion Manager" software, the customer can modify the Speed Controller to special conditions of use. The following parameters can be changed: current limit and regulator parameters.

Circuit diagram / Connection information

Output circuit

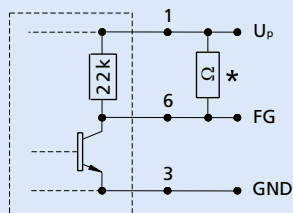

* An additional external pull-up resistor can be added to improve the rise time.
 Caution: I_{OUT} max. 15 mA must not be exceeded!

Cable connection

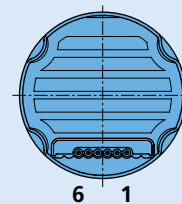

Connection

No.	Function
1	U _p
2	U _{mot}
3	GND
4	U _{nsoll}
5	DIR
6	FG

Caution:
 Incorrect lead connection will damage the motor electronics!

Options

- Connector variant (Option no.: 3809)
 AWG 26 / PVC ribbon cable with connector Micro-Fit



Accessories

- Programming board (Part No.: 6501.00088)

Full product description

- Example:
 2250S024BX4S SC